



## Special Applications • Specific Electrodes for Specific Analysis

**FC 911**  Connector  
**FC 911**  BNC  
**FC 911**  7-pin DIN

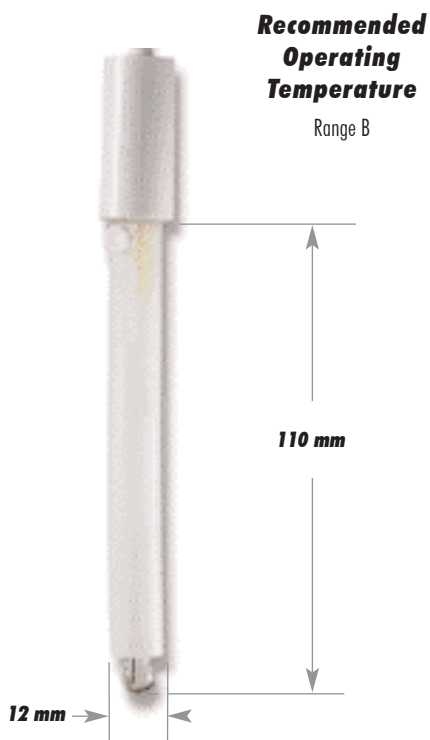

### Reference

Double, Ag/AgCl

### Junction

Ceramic, single

### Electrolyte

KCl 3.5M

### Max Pressure

0.1 bar

### Range

pH: 0 to 13      T: 0 to 80°C (32 to 176°F)

### Tip Shape

Spheric (dia: 7.5 mm)

### Temperature Sensor

No

### Amplifier

Yes

### Body Material

PVDF

### Cable

Bipolar; 1 m (3.3')

### Recommended Use

Creams, fruit juices, sauces

**HI 1292**  Connector  
**HI 1292\***  7-pin DIN

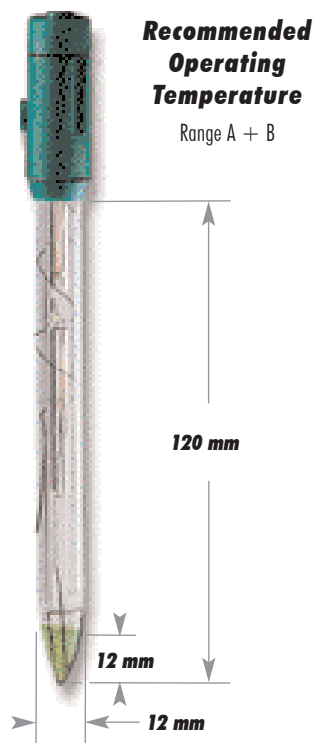

### Reference

Single, Ag/AgCl

### Junction

Ceramic, triple

### Electrolyte

KCl 3.5M + AgCl

### Max Pressure

0.1 bar

### Range

pH: 0 to 12      T: -5 to 100°C (23 to 212°F)

### Tip Shape

Conic (12 x 12 mm)

### Temperature Sensor

Yes

### Amplifier

Yes

### Body Material

Glass

### Cable

7-pole; 1 m (3.3')

### Recommended Use

Direct soil pH measurement, soil solution

\* To be used with HI 99121 (see section D)

**HI 1296**  Connector  
**HI 1296\***  7-pin DIN

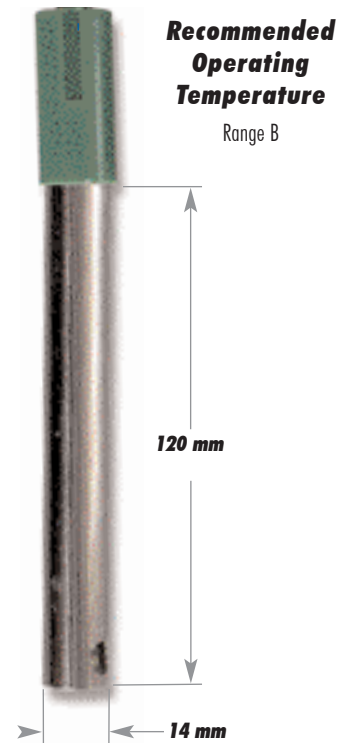

### Reference

Single, Ag/AgCl

### Junction

Cloth

### Electrolyte

Gel

### Max Pressure

3 bar

### Range

pH: 0 to 13      T: 0 to 80°C (32 to 176°F)

### Tip Shape

Spheric (dia: 5 mm)

### Temperature Sensor

Yes

### Amplifier

Yes

### Body Material

Titanium cage

### Cable

5-pole; 1 m (3.3')

### Recommended Use

Wastewater

\* To be used with HI 991001, HI 991002 and HI 991003 (see section D)

## Special Applications • Specific Electrodes for Specific Analysis

### HI 1297 Connector HI 1297\* 7-pin DIN

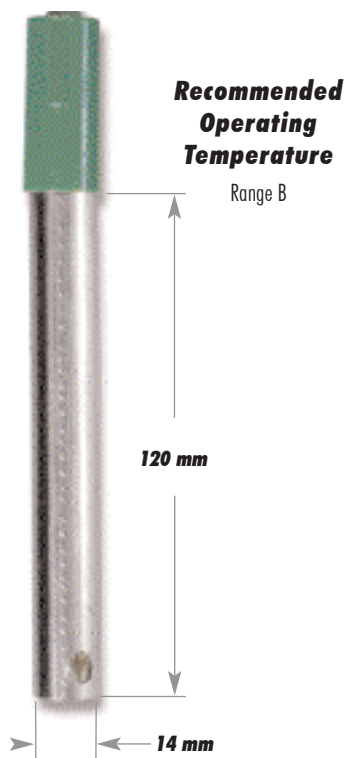

#### Reference

Single, Ag/AgCl

#### Junction

Cloth

#### Electrolyte

Gel

#### Max Pressure

3 bar

#### Range

pH: 0 to 13 / ORP T: 0 to 80°C (32 to 176°F)

#### Tip

pH: Conic (3 mm) ORP: Platinum sensor

#### Temperature Sensor

Yes

#### Amplifier

Yes

#### Body Material

Titanium cage

#### Cable

7-pole; 1 m (3.3')

#### Recommended Use

Wastewater, municipal water, water treatment, swimming pools

\* To be used with HI 991002 and HI 991003 (see section D)

### HI 1413 Connector HI 1413 BNC

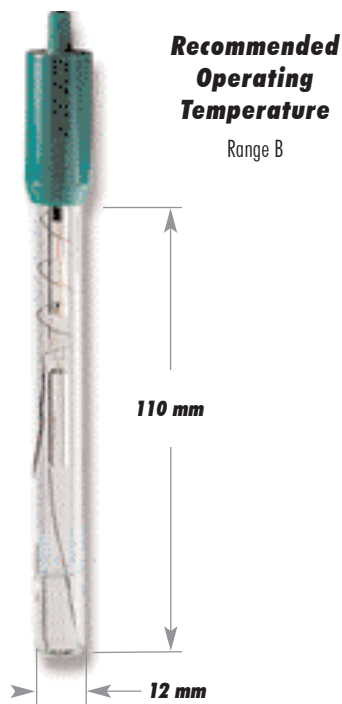

#### Reference

Single, Ag/AgCl

#### Junction

Open

#### Electrolyte

Viscolene

#### Max Pressure

0.1 bar

#### Range

pH: 0 to 12 T: -5 to 50°C (23 to 122°F)

#### Tip Shape

Flat

#### Temperature Sensor

No

#### Amplifier

No

#### Body Material

Glass

#### Cable

Coaxial; 1 m (3.3')

#### Recommended Use

Surfaces, skin, leather, paper, emulsions

### HI 1413 Connector /50

HI 1413  BNC\*

HI 1413  Screw Cap\*

E.g. part number: HI 1413B/50

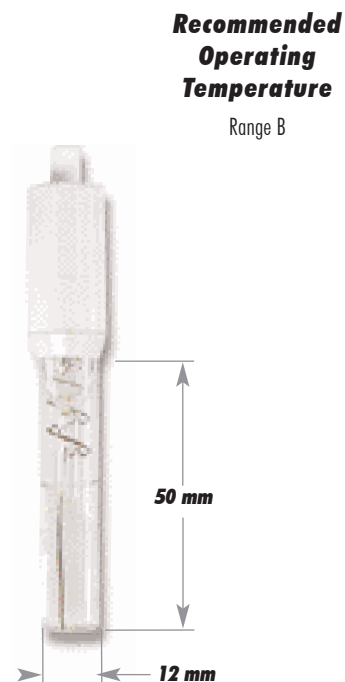

#### Reference

Single, Ag/AgCl

#### Junction

Open

#### Electrolyte

Viscolene

#### Max Pressure

0.1 bar

#### Range

pH: 0 to 12 T: -5 to 50°C (23 to 122°F)

#### Tip Shape

Flat

#### Temperature Sensor

No

#### Amplifier

No

#### Body Material

Glass

#### Cable

Coaxial; 1 m (3.3')

#### Recommended Use

Skin, scalp

\* To be used with *Skinbeck* series (see section B)

\*\* Not for models with screw cap.

## Special Applications • Specific Electrodes for Specific Analysis

**HI 1414** Connector  
**HI 1414** D 7-pin DIN\*



**Recommended Operating Temperature**

Range B

**Reference**

Single, Ag/AgCl

**Junction**

Open

**Electrolyte**

Viscolene

**Max Pressure**

0.1 bar

**Range**

pH: 0 to 12 T: -5 to 50°C (23 to 122°F)

**Tip Shape**

Flat

**Temperature Sensor**

Yes

**Amplifier**

Yes

**Body Material**

Glass

**Cable**

7-pole; 1 m (3.3')

**Recommended Use**

Surface, leather, paper, emulsions

\* To be used with HI 99171 (see section D)

**HI 1414** Connector **/50**  
**HI 1414** D 7-pin DIN\*

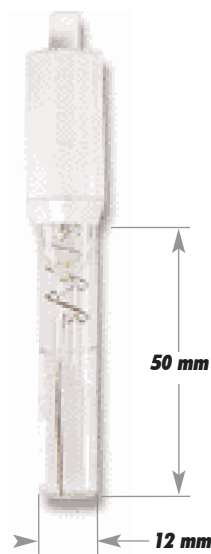

**Recommended Operating Temperature**

Range B

**Reference**

Single, Ag/AgCl

**Junction**

Open

**Electrolyte**

Viscolene

**Max Pressure**

0.1 bar

**Range**

pH: 0 to 12 T: -5 to 50°C (23 to 122°F)

**Tip Shape**

Flat

**Temperature Sensor**

Yes

**Amplifier**

Yes

**Body Material**

Glass

**Cable**

7-pole; 1 m (3.3')

**Recommended Use**

Skin, scalp

\* To be used with HI 99181 (see section D)

The HI 62911 and HI 72911 advanced electrodes with Titanium cage also feature:

1. Annular Teflon® junction for clogging prevention
2. Double junction and polymer electrolyte for enhanced protection against contamination of the reference electrolyte
3. Built-in temperature sensor for automatic temperature compensation and, therefore, accurate readings
4. Built-in amplifier for reducing the effect of electromagnetic interferences, typical of the industrial environments
5. Matching Pin

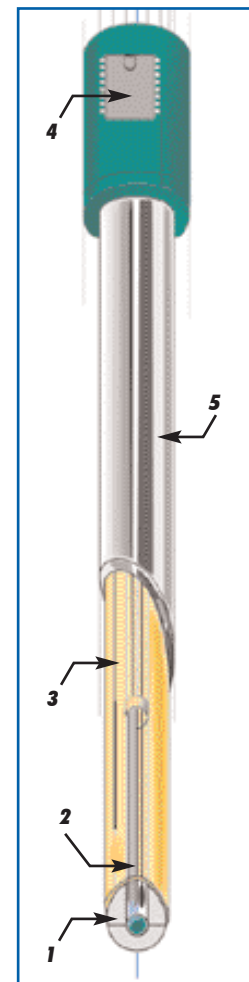

## Special Applications • Specific Electrodes for Specific Analysis

**HI 62911**  Connector  
**HI 62911**  7-pin DIN\*

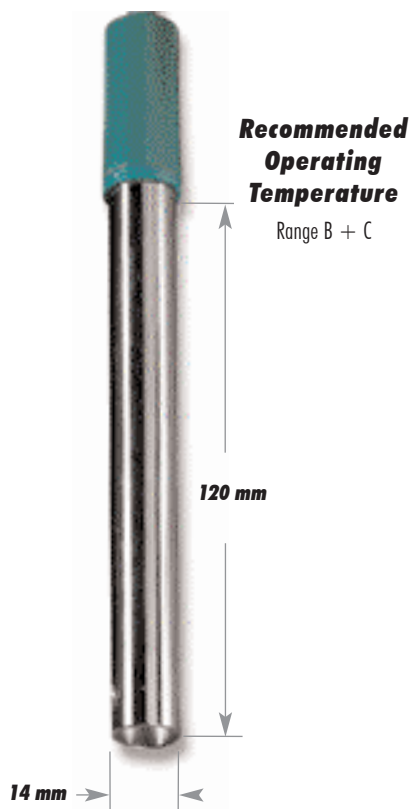

### Reference

Double, Ag/AgCl

### Junction

Teflon®

### Electrolyte

Polymer

### Max Pressure

3 bar

### Range

pH: 0 to 13      T: 0 to 80°C (32 to 176°F)

### Tip Shape

Flat

### Temperature Sensor

Yes

### Amplifier

Yes

### Body Material

Titanium cage working as Matching Pin

### Cable

7-pole; 1 m (3.3')

### Recommended Use

Plating baths

\* To be used with **HI 99131** (see section D)

**HI 62920**  Connector  
**HI 62920**  7-pin DIN\*

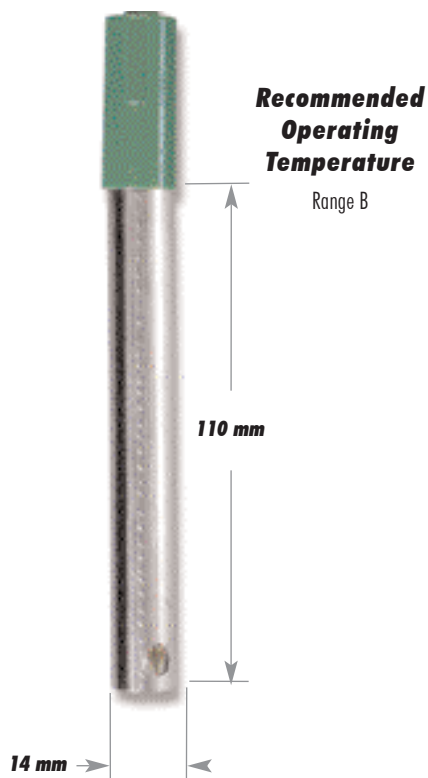

### Reference

Double, Ag/AgCl

### Junction

Teflon®

### Electrolyte

Polymer

### Max Pressure

3 bar

### Range

pH: 0 to 13      T: 0 to 80°C (32 to 176°F)

### Tip Shape

Flat

### Temperature Sensor

Yes

### Amplifier

Yes

### Body Material

Titanium cage working as Matching Pin

### Cable

7-pole; 2 m (6.6')

### Recommended Use

Industrial applications

\* To be used with **HI 504920** (see section T1)

**HI 72911**  Connector  
**HI 72911**  7-pin DIN\*

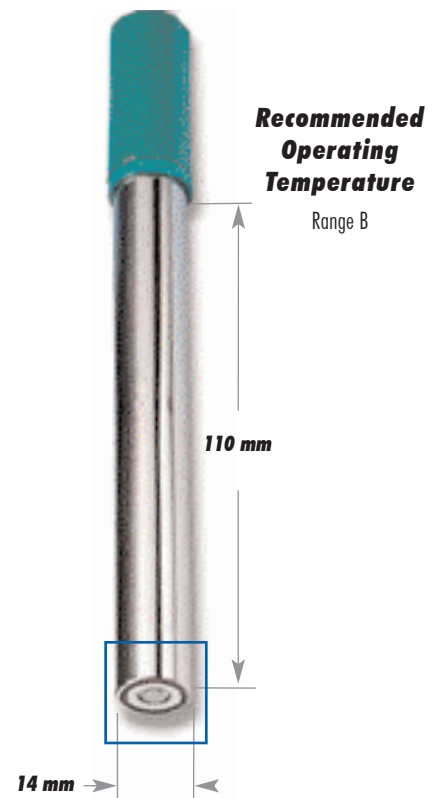

### Reference

Double, Ag/AgCl

### Junction

Teflon®

### Electrolyte

Polymer

### Max Pressure

3 bar

### Range

pH: 0 to 13      T: 0 to 80°C (32 to 176°F)

### Tip Shape

Flat

### Temperature Sensor

Yes

### Amplifier

Yes

### Body Material

AlSI 316 working as Matching Pin

### Cable

7-pole; 1 m (3.3')

### Recommended Use

Cooling towers, boilers

\* To be used with **HI 99141** (see section D)